

## Stair Installation Classic Traditional and Classic American

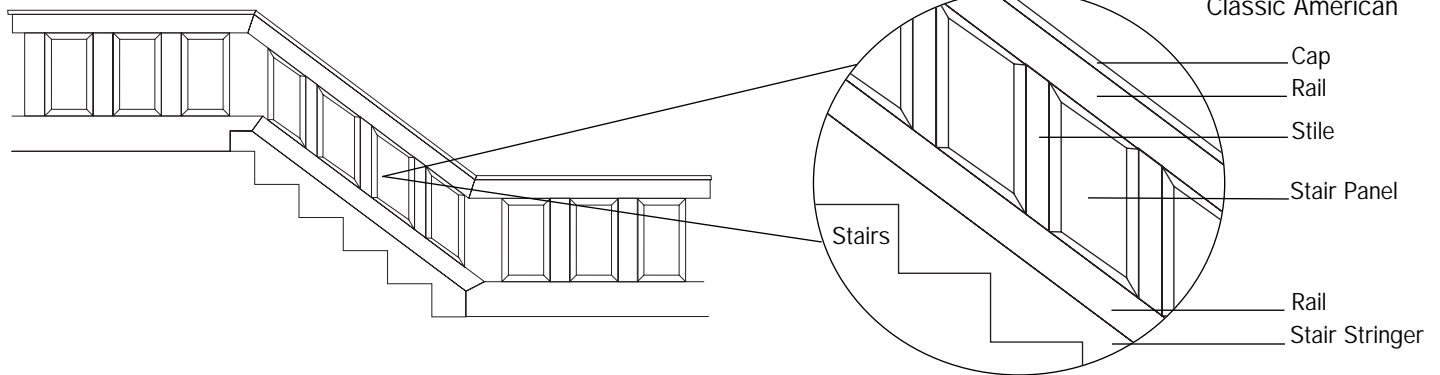

### STEP 1.

Choose either a 4" or 8" bottom rail and mark its height on wall at top and bottom of stairs. Cut bottom rail A to fit the stair stringer and install.

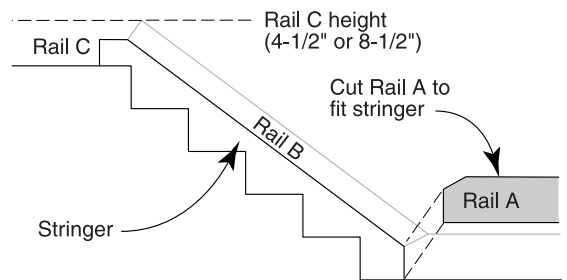

### STEP 2.

Holding Rail B (4" rail recommended) against the stair stringer, mark and cut the bottom end of Rail B to fit Rail A, then mark and cut the top of Rail B as shown.

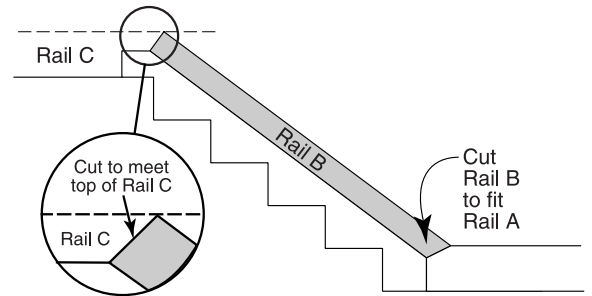

### STEP 3.

Mark centerlines of a panel. From the intersection, measure up and down 10-1/8". Through these points draw lines at the angle of the stairs and trim panel(s).

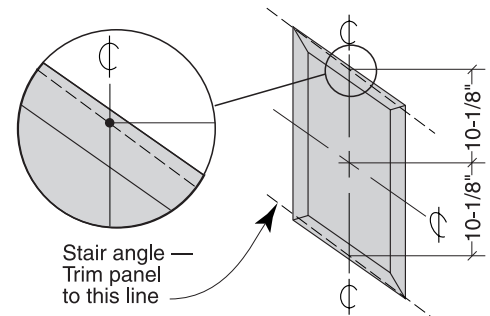

### STEP 4.

Draw two stair-angle lines 20-1/4" apart on a stile and cut along the lines. Cut dados (see detail) in the ends so that the exposed length is 19-1/2".

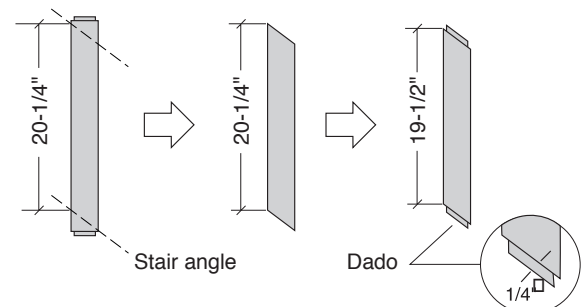

### STEP 5.

Using panels as guides, draw horizontal and inclined lines on the wall showing panel heights. Locate Point A and Point B (intersection of lines just drawn, as shown).

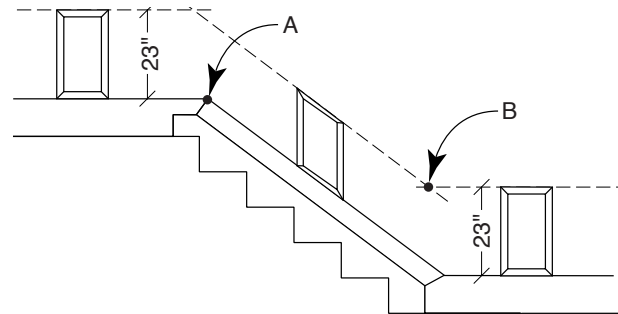

### STEP 6.

Draw vertical lines through Points A & B. Lay out panels and stiles from Steps 3 & 4 so that there are equal gaps between the end panels and lines A & B.

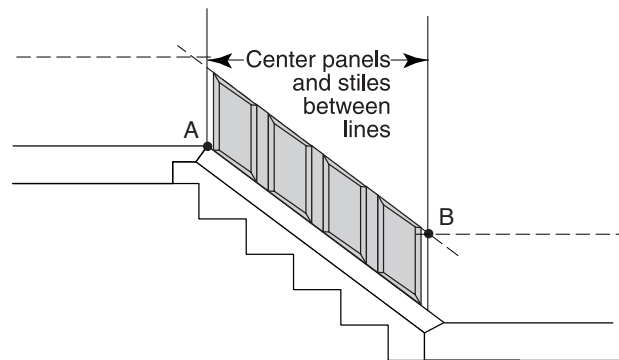

### STEP 7.

At top and bottom of stairs, mark and trim 10" stair stiles to make the transitions between regular panels and inclined stair panels. After trimming the stiles, dado the fresh cuts.

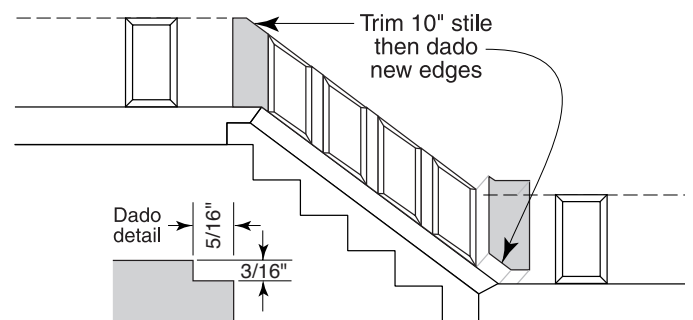

### STEP 8.

After placing all panels and stiles, cut top rails and slide into place. Pre-drill holes in nailing groove at studs and fasten with 8d finish nails. Cut caps and fasten to top rails with adhesive and a few 4d finish nails.

